

This publication supersedes and replaces any previous edition and revision. All rights reserved. No part of this publication may be reproduced, stored in a retrieval system or transmitted in any form or by any means, electronic, mechanical, photocopying, recording or otherwise, without permission of Tecnicam s.r.l. (Bologna - Italy). The technical data, the images and the diagrams are exclusively indicative and not binding, they might be modified without notice.

NTW600

High speed Intermittent motion
wrap-around case-packer

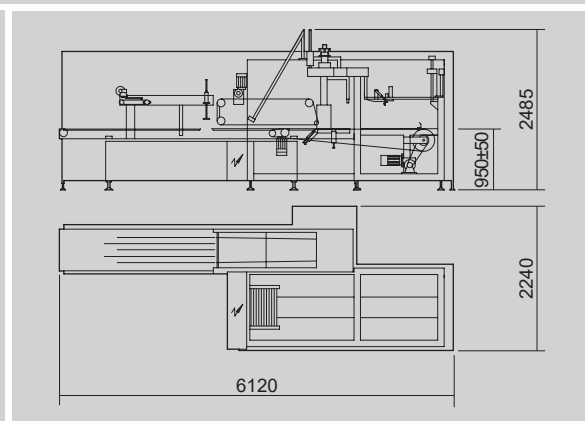
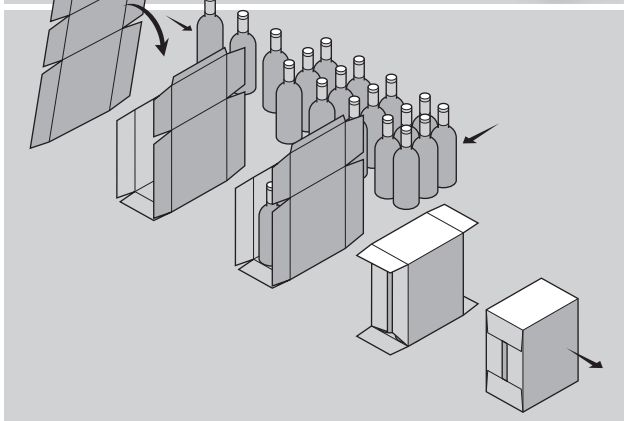

TECHNICAL DATA

Mechanical speed	STROKES/1'	25
Power absorption (max.)	KW	8
Air consumption	NI/1'	22
Air pressure	bar	6
Gross weight	kg	~2000
Net weight	kg	~1800

Size range	min.	max.
d_i	100	360
e_i	190	500
f_i	70	360
H	40	150

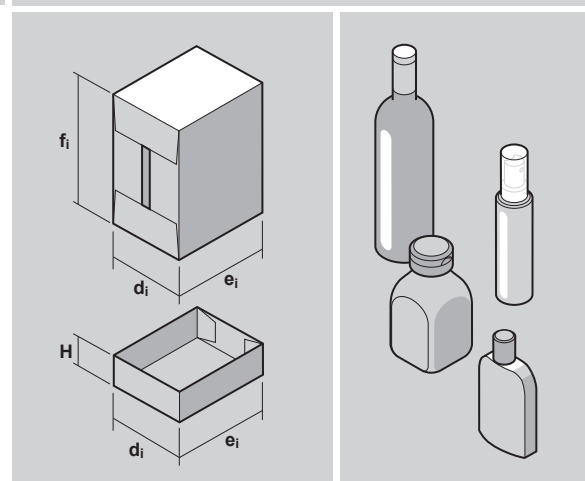

FM-NTW600-02-uk (10/02/2018)